



E85263-00



# CREWMAN™

## Dust Control 20" Battery Burnisher



### Operator and Parts Manual

# TABLE OF CONTENTS

Technical Description .....	3
General Safety.....	4
Loading, Unloading and Transporting .....	5
Battery Charger Operation.....	6
Battery Charger Settings .....	7
Setup, Operation & Pad Pressure Adjustment .....	8
Battery Discharge Indicator.....	9
Pad Installation Instructions .....	10
Assembly .....	11
Parts Diagrams .....	12 - 21
Parts Listing.....	22 - 23
Maintenance.....	24
Troubleshooting .....	25
Warranty .....	28

<b>TECHNICAL DESCRIPTION</b>	<b>Measurement Unit</b>	<b>Crewman™ Dust Control Battery Burnisher</b>
Burnish path	in (mm)	20 (508)
Pad size	in (mm)	20 (508)
Motor	HP	2.5
Motor speed	RPM	2000
Pad driver		Flexible
Pad Pressure		Adjustable
Volts	V	36
Batteries	V / AH	(3) Maintenance free, 12-volt, 110 AH, AGM
Run time		Up to 2.5 hour
Charger		Onboard, high frequency computer controlled
Battery/hour meter		Yes, BDI computer controlled
Key switch		Yes
Safety switch		Yes
Construction		Powder coated steel frame, plated steel handle
Main Wheels (non-marking)	in (mm)	8 (203)
Rear Wheels (non-marking)	in (mm)	4 (101.6)
Machine dimensions (Length / Height / Width)	in x in x in (mm/mm/mm)	41 x 39 x 22 (1041 / 991 / 559)
Weight of machine (including batteries)	lb. (Kg)	326 (148)
Productivity	sq.ft/hr.	Up to 20,000

# GENERAL SAFETY REGULATIONS

**WARNING: This manual contains important information about your machine. Read and understand all instructions before operating the machine. Failure to read and follow the instructions could result in injury to the person operating the machine or injury to others. Damage to the machine or other property could occur if instructions are not followed.**

- Do not operate this machine around any solvents, thinners, or other flammable liquids or materials. Electrical sparks can cause a fire or even an explosion.
- Do not smoke around the machine. Also, keep all sparks and flames away from the batteries. The batteries generate gases that can cause an explosion.
- Special care needs to be used when working on or near the batteries. Wear eye protection. Do not lay tools on batteries, as they may short out battery terminals. Do not wear metal jewelry, as it may short out battery terminals.
- Charging batteries can be dangerous. Be aware that the battery charger may have a relatively low voltage output, but the current output is very high and therefore dangerous. Do not operate the charger if any parts of the charger or charger cords are damaged. Do not stand on a wet floor when connecting or disconnecting charger to the power outlet or to the machine.
- Battery acid is dangerous. Wear eye and face protection, hand protection, and body protection when working on and around batteries. If you get acid on your skin, wash off immediately. If you get acid on your clothing, remove clothing and wash any skin that was in contact with the clothing. Baking soda mixed with water will help to neutralize the acid on your skin.
- The machine is very heavy, so be very careful when loading, transporting, and unloading the machine.
- Keep all body parts, clothing, and objects away from moving parts.
- Operate machine from the rear, not from the side.
- Disconnect a wire to the batteries before working on the machine.
- Do not operate machine with charger plugged in.
- Never disconnect the battery while charging, since this could cause sparks.
- Never use the equipment in the rain, in areas used for washing, or in wet or damp areas.
- Use battery chargers only in well ventilated areas.
- Do not operate machine with any parts damaged or missing.
- Do not operate close to stairs, loading docks, or other drop-offs. Do not park machine in such a manner that it could roll, forward or backward, off a drop-off.
- Authorized personnel must perform maintenance and repairs. Do not alter or modify the machine, unless authorized by the manufacturer.
- Do not expose the electrical components to water or excessive moisture.
- Always put caution signs around the areas that are being cleaned.
- Do not use machine as a “ladder”. Do not use machine as a “forklift” to push stuff around. Do not ride or let anyone ride on the machine.
- Your machine warranty may be voided if parts other than Betco parts are used.

# LOADING, UNLOADING AND TRANSPORTING

**DANGER: The machine is very heavy, so be very careful when loading, transporting, and unloading the machine. Use at least two people to load or unload the machine.**

## **LOADING PROCEDURE USING A RAMP**

- It is not recommended that the battery burnisher be loaded using a ramp with an incline of more than 7 degrees. The machine is not self-propelled and therefore it is not able to assist itself up a ramp. It is too heavy to manually push up a steep incline.
- If you must load with a ramp, the incline must be no more than 7 degrees. (This would permit a height of no more than one foot for an 8-foot ramp).
- Ramp must be secured to vehicle, and be clean and dry.
- Machine must be pushed or pulled straight up the ramp and never at an angle.

## **LOADING PROCEDURE USING A LIFT GATE**

- Lift gate must have ample capacity to lift the burnisher.
- Wheels must be firmly chocked to prevent burnisher from rolling off the lift gate.

## **SECURING BATTERY BURNISHER**

- Burnisher must be secured, so that it will not roll or turn over. Use chocks and tie downs to secure.
- Please be aware that the battery burnisher is very heavy, and that a metal bulkhead in a van may not contain equipment in the event of an accident. The equipment in a van can be more dangerous than the accident itself.

## **UNLOADING PROCEDURE USING A RAMP**

- Ramp must be long enough so that removal can be controlled. Use same ramp incline restrictions as used for loading burnisher.
- Ramp must be secured to vehicle, and be clean and dry.
- Machine must be taken straight down the ramp and never at an angle.
- Do not let machine run over you or anyone else as it comes off ramp.

# BATTERY CHARGER OPERATION

## CHARGER OPERATION

- Plug the cord from the charger into a 110 volt outlet.
- Batteries should now start charging.
- A test is run on the battery voltage to decide if the charging process should be started or not. If the battery is not connected to the battery charger, the display will show the word “bat”. The word will stay on, even if the test is failed (for instance, reversed polarities or incorrect battery connection). If the test is passed, the display will show the battery voltage for approximately 5 seconds and the battery will begin to be charged. The charging cycle progress will be shown by red, yellow, and green LED indicators. At the end of the charge, when the green indicator is on, unplug the cord from the socket and operate the machine.
- It is suitable for any battery type, if the charger has the proper settings. (Call manufacturer of machine on how to set the charger for different batteries than were supplied with your machine).
- **NOTE: THE MACHINE WILL NOT POWER ON IF THE CHARGER IS STILL PLUGGED IN TO THE 110 VOLT OUTLET.**

## INDICATOR LIGHTS

- Red indicator shows that the charging cycle has started.
- Yellow indicator shows that the final phase of the charging cycle has started.
- Green indicator shows that the charging cycle has finished.





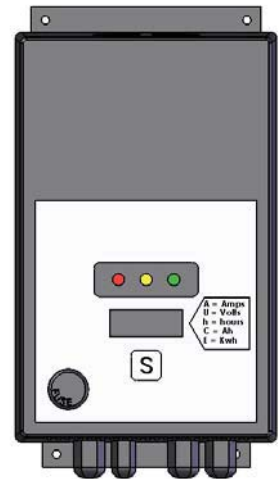

## DISPLAY

Press button “S” (for Selection) to display:

- A = the charging current,
- U = the battery voltage,
- H = the charging time,
- C = the charging ampere-hours [Ah],
- E = the energy used [KWh].
- **CAUTION: CHARGER SETTINGS MUST BE CHANGED IF BATTERY TYPE IS CHANGED. THIS BATTERY CHARGER IS FACTORY SET FOR THE TYPE OF BATTERIES THAT CAME WITH YOUR MACHINE. IF YOU SWITCH BATTERY TYPES, THEN THE BATTERY CHARGER MUST BE REPROGRAMMED.**

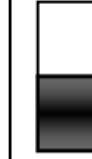

# BATTERY CHARGER SETTINGS

ON	ON	ON	ON	ON	ON	ON	ON
							
OFF	OFF	OFF	OFF	OFF	OFF	OFF	OFF
DIP 1	DIP 2	DIP 3	DIP 4	DIP 5	DIP 6	DIP 7	DIP 8

## DIP SWITCH INFORMATION

The battery charger that was provided with the equipment is a programmable battery charger that can be optimized to the specific battery pack supplied with the machine. To access the programming DIP Switches you must remove the hard plastic label on the front of the charger. Be certain that the battery charger is unplugged from supply AC voltage and be certain that the battery charger is disconnected from the battery pack. Below is the correct charger settings for the battery pack provided with the machine.

OFF	ON	OFF	ON	ON	ON	ON	OFF
Dip 1	Dip 2	Dip 3	Dip 4	Dip 5	Dip 6	Dip 7	Dip 8

## INITIAL SETUP AND OPERATION

1. Remove the hardware from the Manual bag.
2. Raise the handle to the operating position and fasten with the two 1/2" x 5/16" bolts (A).
3. Tighten the other two bolts securely (A).
4. Hook the lanyard on the 1" bolt on left side of the machine and fasten it with the Ny-Lok nut supplied.
5. Cut the bands, remove the wheel chocks, lean the machine back so that the small wheels are touching the pallet, roll the machine forward and lower the large wheels to the floor. Tip the machine up into the operating position.
6. Tip machine back and ensure the center lock is tight. (See "Pad Installation Instructions" on page 10).
7. Connect the positive + cable to the + post on the upper battery (B).
8. Remove the key from the manual bag and insert it in the key switch located under the battery box cover (C).
9. To operate the machine turn on the key switch, release the safety lock and squeeze the trigger on the handle (D).
10. The machine is equipped with the high speed burnishing pad that was used in testing the machine and is ready to run.

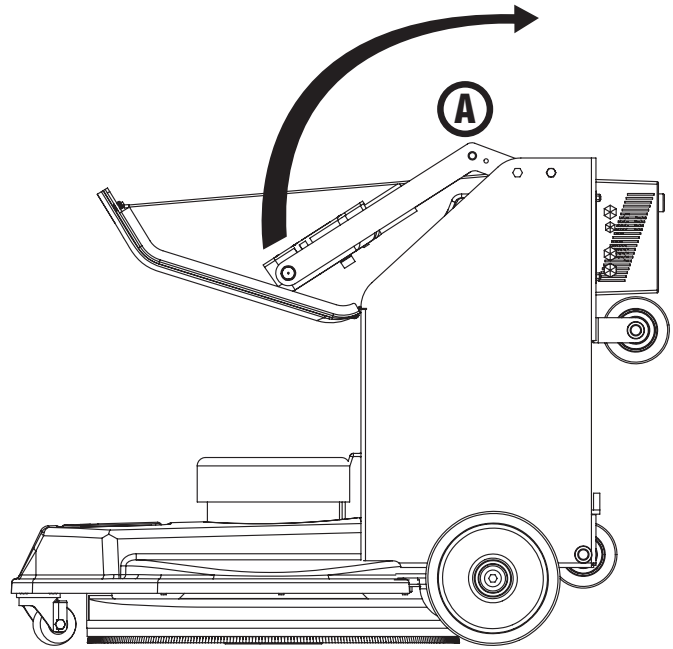

## PAD PRESSURE ADJUSTMENT

1. The machine is equipped with a manual pad pressure adjustment knob (E) and meter (F).
2. To increase pad pressure, open the battery compartment cover and turn the knob (E) counter-clockwise.
3. The pressure meter (F) will move up as the pad pressure is increased.
4. To decrease pad pressure, open the battery compartment cover and turn the knob (E) clockwise.
5. The pad pressure should be decreased if the pressure meter is in the red. Use of the machine with too much pad pressure will trip the circuit breaker.

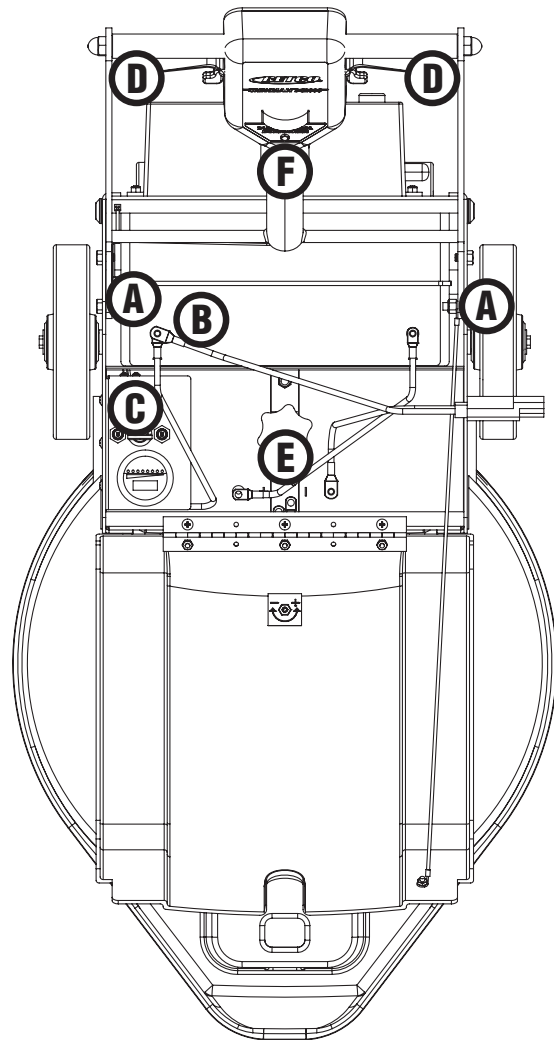



# BATTERY DISCHARGE INDICATOR

## CONNECTOR PIN CONFIGURATION (A)

1. Hour meter input –
2. Key +
3. Relay +
4. Relay –
5. Battery –
6. Not used
7. Not used
8. Battery +

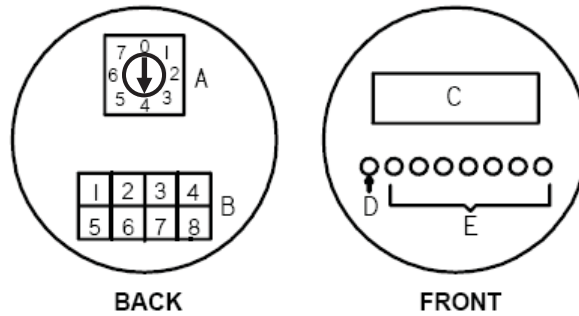

- A. Shutoff voltage rotary dip switch. Factory set to 4 (32.76 volts). This is the voltage at which the batteries are 80% discharged. Do not set below this voltage or battery life will be shortened.
- B. Connector to meter (molex connector)
- C. Hour meter (display is always on, but only counts time when negative voltage is applied to pin 1)
- D. Low voltage shutoff LED
- E. Battery condition LED's. (1 through 7 with 7 being fully charged batteries)

Position	0	1	2	3	4	5	6	7
Volts per Cell	1.63	1.68	1.73	1.76	<b>1.82</b>	1.84	1.86	1.89
Total Volts	29.34	30.24	31.14	31.68	<b>32.76</b>	33.12	33.48	34.02

## FUNCTION

The battery level indicator is a device that helps protect the machine's batteries from damage caused by over-discharging the batteries. The indicator also lets the machine operator know when the batteries need to be recharged. When the machine is turned on, the battery level indicator continuously monitors the battery voltage. Typical output of the indicator is as follows:

- If the battery voltage is below the shutdown voltage, the machine will either be turned off or will not be able to start. If the machine is in operation when the shutdown voltage is reached, the outside (right most) yellow LED will flash for 15 seconds and then the red LED, "D", will be turned on. The machine will be turned off automatically. The batteries should be charged.
- If the battery voltage is at a satisfactory state of charge, some number of the yellow LEDs will turn on. The increasing quantities of illuminated yellow LEDs indicate higher states of battery charge. The machine will be able to be turned on and operated.
- If the battery voltage is above, but is very close to the shutdown voltage when the machine is turned on, some of the yellow LEDs will flash and the batteries will need to be charged before the machine is placed into operation.

## SETTINGS

Turn the machine off and disconnect the batteries. Locate the rotary selector switch located on the back of the Battery Level Indicator. The rotary selector switch is switch "A" shown in the diagram above. Gently rotate the switch so that the arrow is pointing at the number 4. Doing this sets the system shutdown voltage to 32.76 VDC. Never set the selector switch to any other position because battery damage or decrease operating time will be experienced.

# PAD INSTALLATION INSTRUCTIONS

1. Use only 19" or 20" diameter pads. Light hair pads work the best.
2. Turn the key switch off.
3. Tip the machine all the way back.
4. Remove the center lock (A).
5. Center the new pad on the pad holder, feel around the edges to ensure that the pad is centered.
6. Install the pad center lock (A) with the black gripper ring to hold the pad. Tighten the center lock securely.
7. Tip the machine up and press down on top of the motor to help seat the pad on the pad holder.
8. Turn the key switch to on and adjust the pad pressure to the desired level.

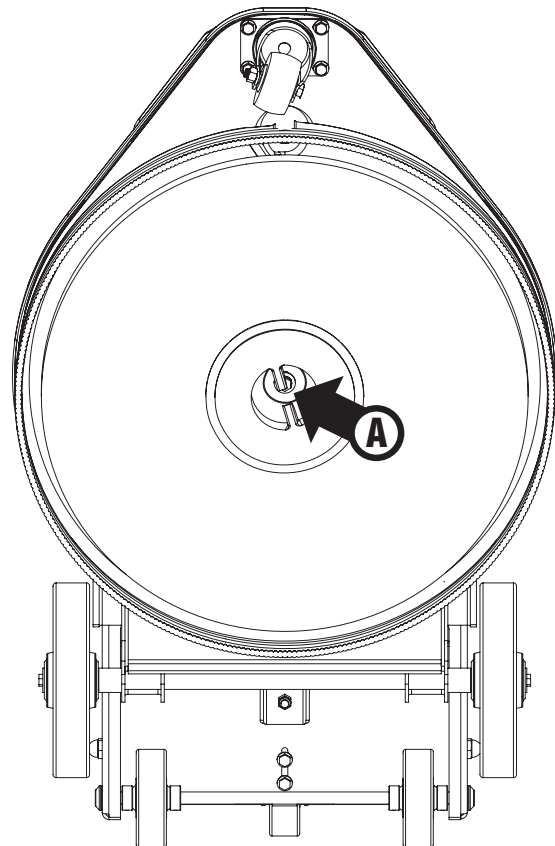
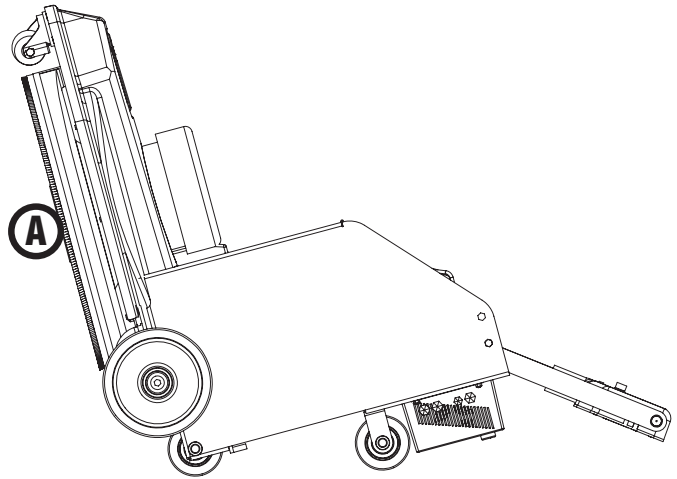

# ASSEMBLY

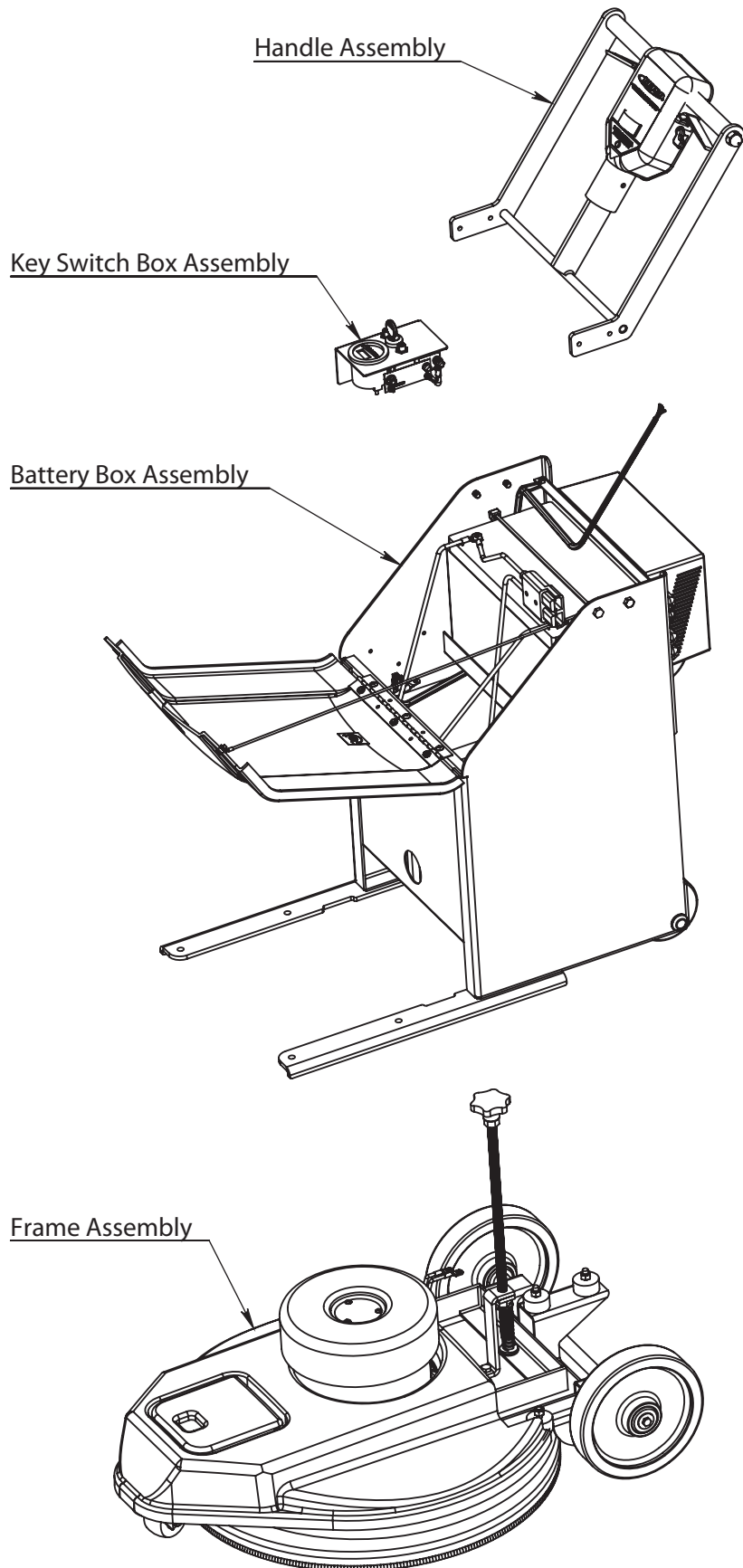

# HANDLE ASSEMBLY PARTS DIAGRAM

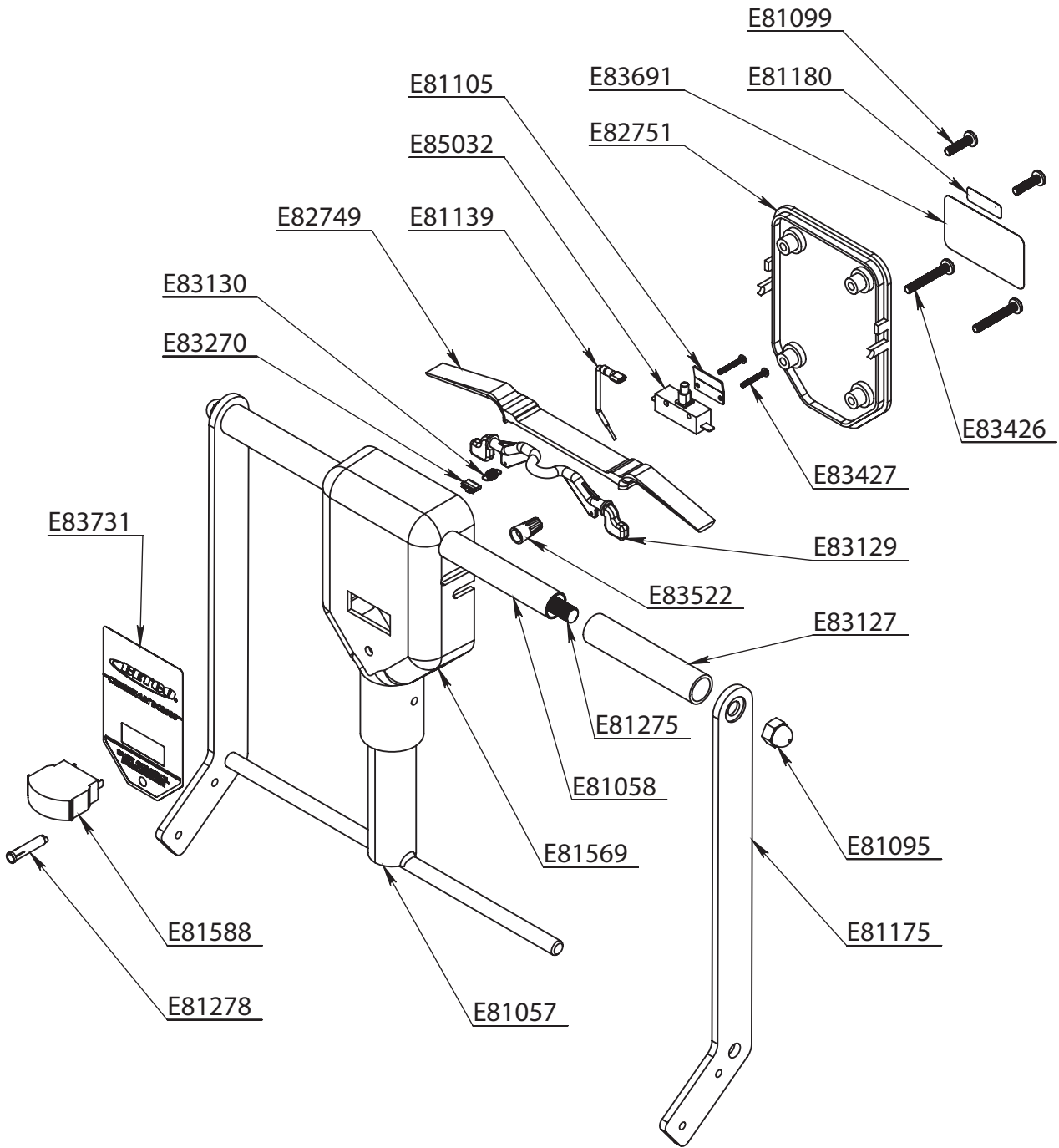

## HANDLE ASSEMBLY PARTS LISTING

PART NUMBER	Description	QTY.
E81057	DCBB Handle Tube Weldment	1
E81058	Handle Tube, 0.880" OD x 0.047" Wall x 14.375"	1
E81095	Nut, 1/2"-13, Acorn, Zinc	2
E81099	Screw, 1/4"-20 x 1.000", Pan Head	2
E81105	Plate, Switch	1
E81139	Wire, 16 AWG, Black, 4.00" L, 1 Female QD	1
E81175	Bracket, Handle Leg DCBB	2
E81180	Serial Number Decal	1
E81275	Threaded Rod, 1/2"-13 x 15.875"	1
E81278	Pilot Light 36 VDC	1
E81569	Switch Box, Battery Burnisher	1
E81588	Meter 50 mV 1-50 AMP, Scale Green 0-40	1
E82749	Handle Trigger Switchbox	1
E82751	Cover, Switch Box	1
E83127	Handle Grip 7/8" ID	2
E83129	Safety Lock	1
E83130	Spring, Extension 0.026 Wire x 0.686 L	1
E83270	Spring Clip	1
E83426	Screw, 1/4"-20 x 1.750, Pan Head	2
E83427	Screw, #6-32 x 1.00", Pan Head	2
E83522	Wire Nut, Yellow	2
E83691	Decal, Warning	1
E83731	Decal, Handle, Dust Control Burnisher	1
E85032	Switch, 25 AMP, 1.5 HP, 125 VAC	1

Note: Not available for purchase assembled.

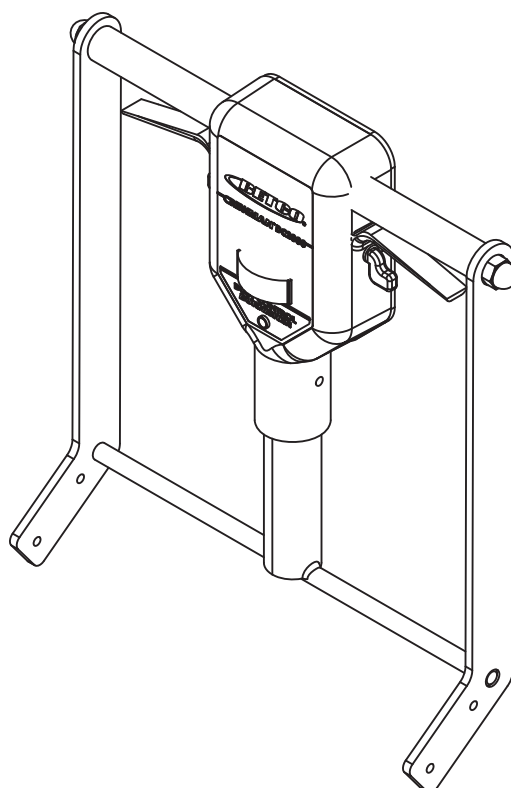

# KEY SWITCH BOX ASSEMBLY PARTS DIAGRAM

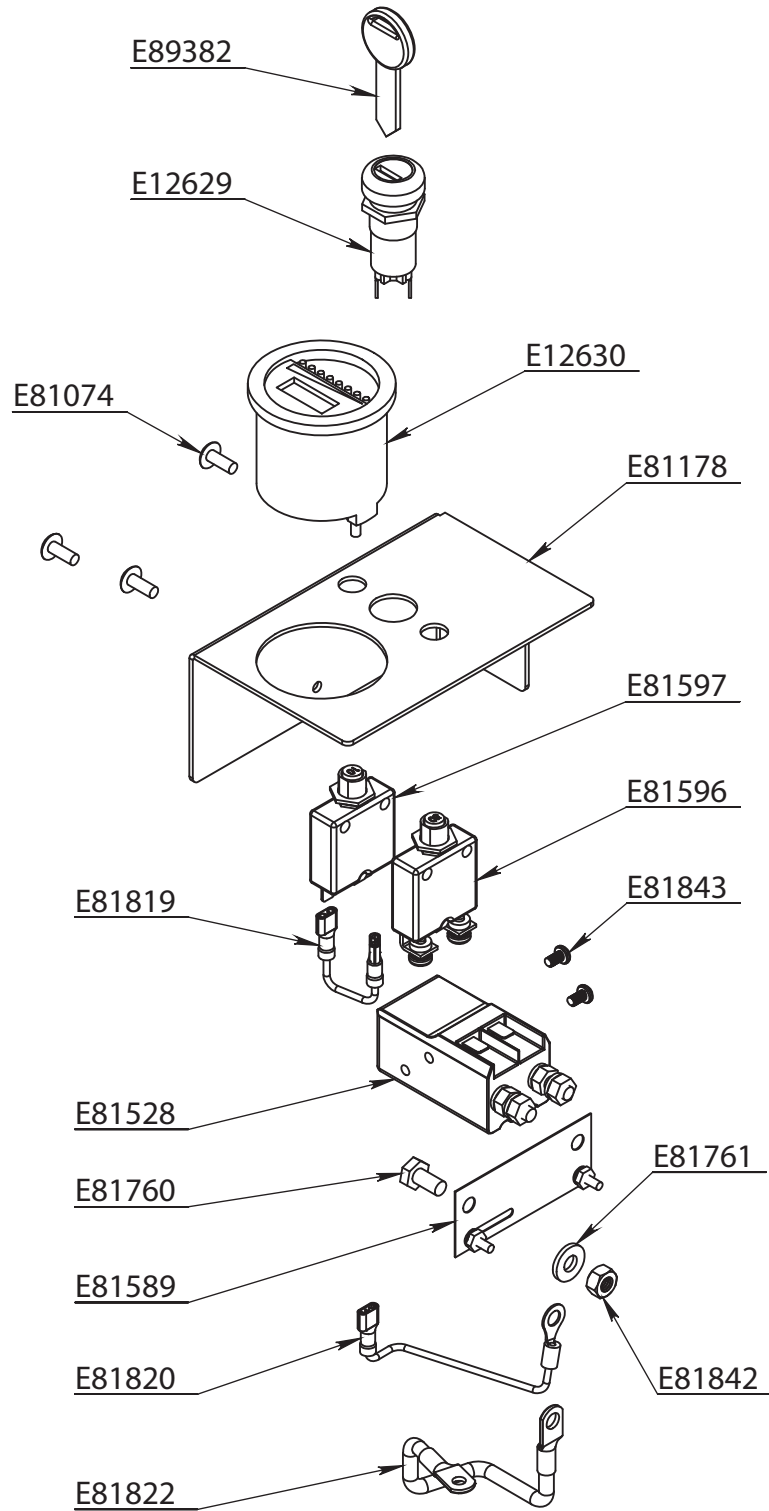

# KEY SWITCH BOX PARTS LISTING

PART NUMBER	Description	QTY.
E12629	Switch, Keyed, SPE, With 2 Keys	1
E12630	Hour Meter, BDI	1
E81074	Screw, #10-24 x 0.500" Pan Head, Zinc	3
E81178	Bracket, Hour Meter	1
E81528	Contactora 36VDC, 72 Amp	1
E81589	Shunt, 50 AMP, 50 mV	1
E81596	Manual Reset Circuit Protector 50 AMP	1
E81597	Manual Reset Circuit Protector 10 AMP	1
E81760	Screw, 1/4"-20 x 3/4" Hex Head, Brass	1
E81761	Washer, 1/4" SAE, Brass	1
E81819	Wire, 16 AWG, Red, 4.00" L, 2 Female QD	1
E81820	Wire, 16 AWG, Red, 6.00" L, Female QD & Ring 0.250"	1
E81822	Cable, 6 AWG, Red, 6.00" L, Lug #10 & Lug 0.250"	1
E81842	Nut, 1/4"-20, Hex Head, Brass	1
E81843	Screw, M4 x 7mm, Pan Head, Zinc	2
E89382	Key, Switch	1

Note: Not available for purchase assembled.

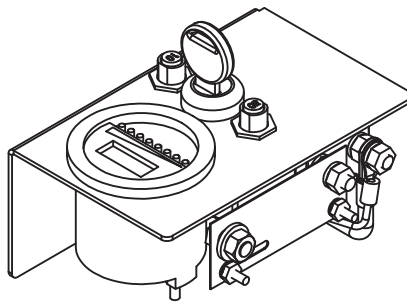

# BATTERY BOX ASSEMBLY PARTS DIAGRAM

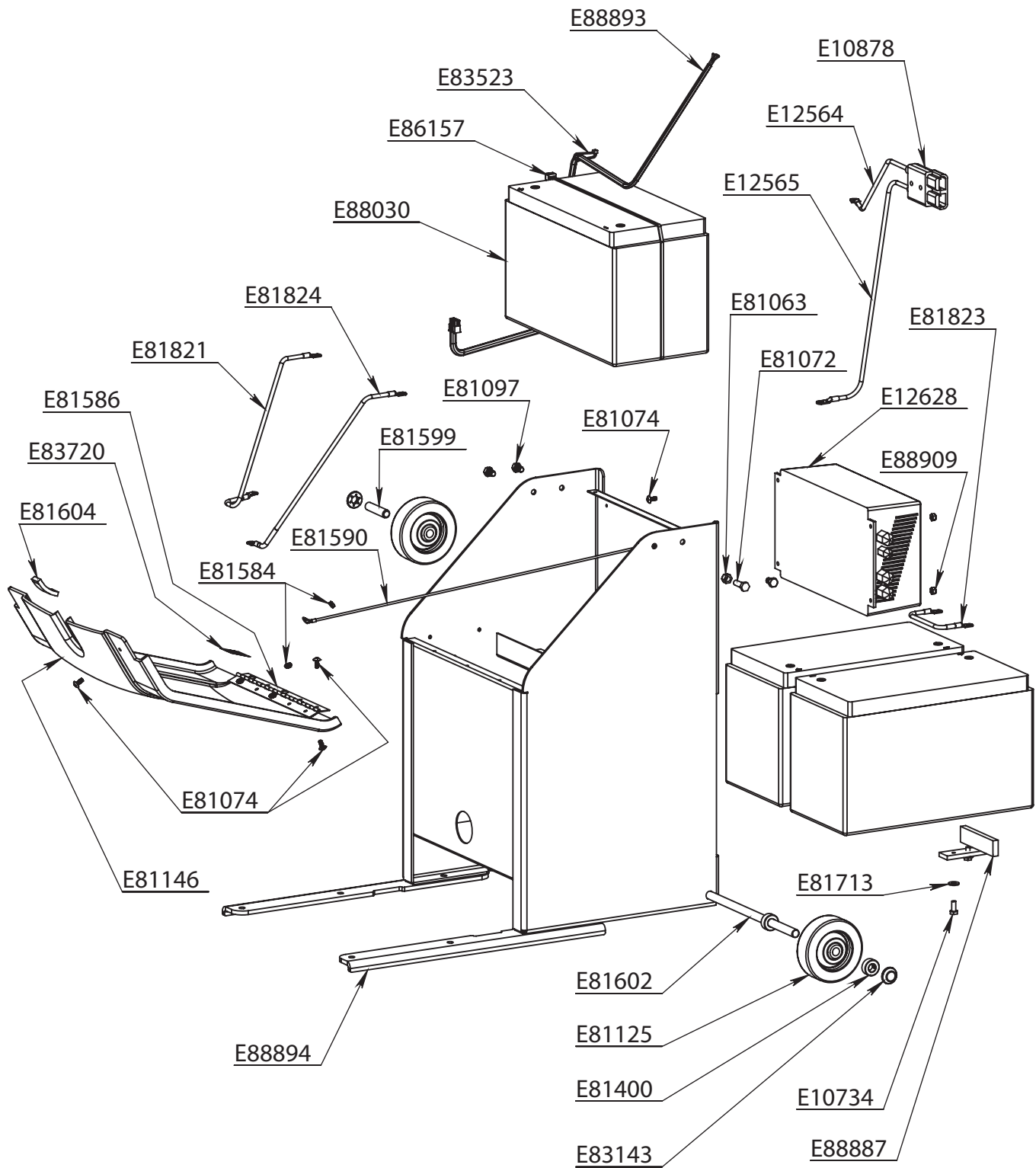



# BATTERY BOX PARTS LISTING

PART NUMBER	Description	QTY.
E10734	Screw, 1/4"-20 x 0.625 Hex Head, Grade 5, Zinc	2
E10878	Anderson Plug, Gray	1
E12564	Cable, 4 AWG, Red, 27.50" L, Lug 0.250" & Anderson Contact	1
E12565	Cable, 4 AWG, Black, 23.50" L, Lug 0.250" & Anderson Contact	1
E12628	Charger, SPE, 36V, 15A, AGM	1
E81063	Nut, 5/16"-18, Nylon Lock, Grade 5, Zinc	1
E81072	Screw, 5/16"-18 x 1.00" Hex Head, Grade 5, Zinc	1
E81074	Screw, #10-24 x 0.500" Turss Head, Zinc	11
E81097	Screw, 5/16"-18 x 0.500", Grade 5, Hex, Zinc	3
E81125	Wheel, 4" OD, 1/2" ID, Non Marking	3
E81146	Cover, Battery, DCBB	1
E81400	Collar, Shaft 0.500" ID, Set Screw	4
E81584	Nut, #10-24, Zinc	7
E81586	Hinge, Piano, 10.00" x 1.50", Steel, Chrome	1
E81590	Lanyard, 0.065" x 24.00" L	1
E81599	Axle, 0.500" OD x 2.250" L	1
E81602	Axle, 0.500" OD x 15.375" L, Zinc	1
E81604	Gasket, 3/4" x 1/4" x 4.0"	2
E81713	Washer, 1/4" SAE, Zinc	2
E81821	Cable, 6 AWG, Red, 21.50" L, Lug 0.250" & Lug #10	1
E81823	Cable, 6 AWG, Black, 6.50" L, 2 Lugs 0.250"	1
E81824	Cable, 6 AWG, Black 23.50" L, 2 Lugs 0.250"	1
E83143	Axle Cap 0.500"	4
E83523	Cable Tie, 4.125in L x .125in W x 0.060 T, Nylon	1
E83720	Decal, Adjustment Dust Control	1
E86157	Cable Tie, 6.0' L x 0.350" W x 0.070" T, Nylon	1
E88030	Battery, Crown, 12 VDC, 110 AH, AGM	3
E88887	Bracket, Battery Support Weldment	1
E88893	Wire Harness, 16 AWG, 6 Wire, Molex 5557-08R Connector	1
E88894	Battery Box Weldment	1
E88909	Nut, #10-24, Nylon Lock, Grade 5, Zinc	4

Note: Not available for purchase assembled.

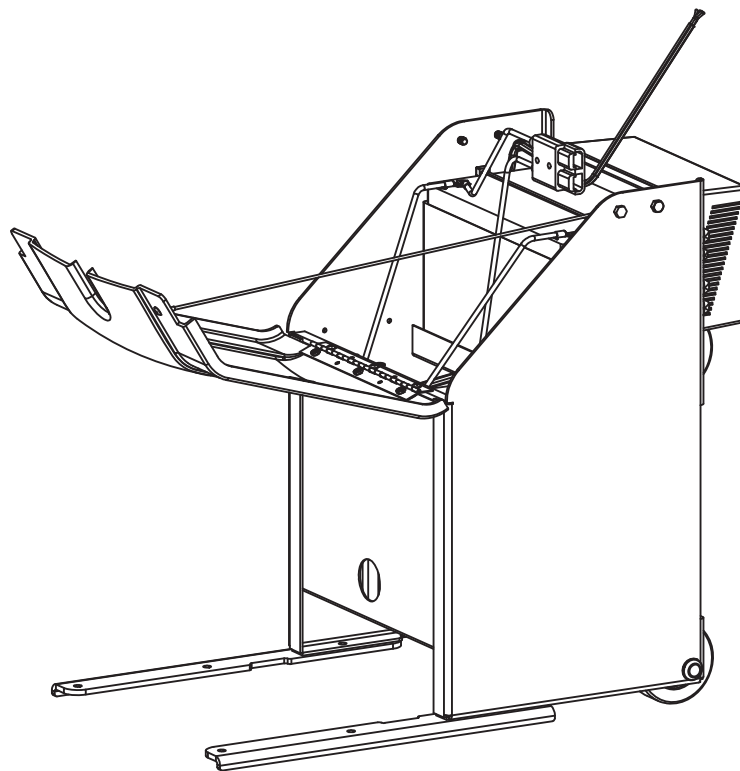

# FRAME ASSEMBLY PARTS DIAGRAM

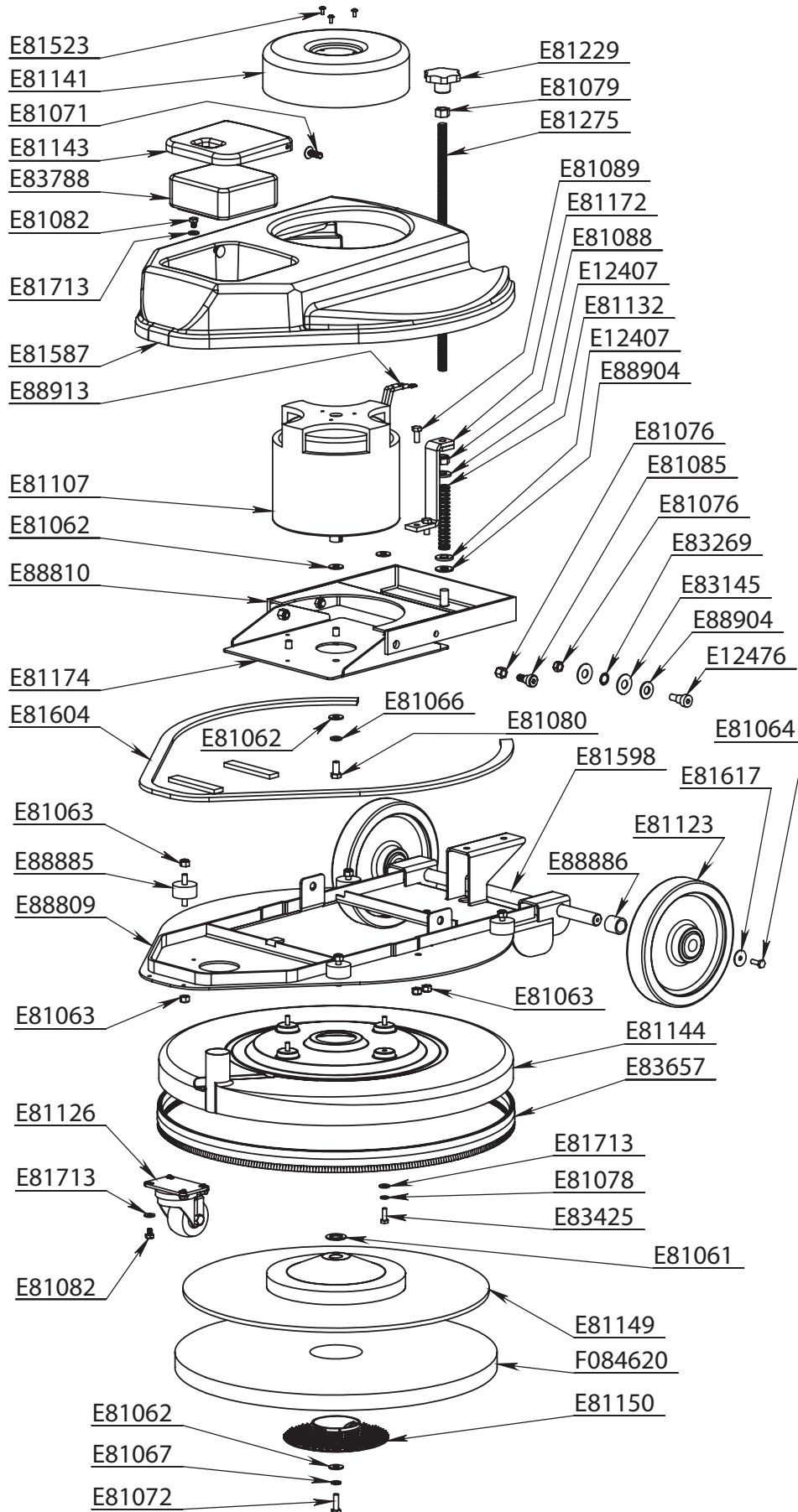

# FRAME BOX PARTS LISTING

PART NUMBER	Description	QTY.
E12407	Washer, 1/2" SAE, Zinc	2
E12476	Screw, Shoulder 1/2" x 1/2" Socket Head	2
E81061	Washer, Flat 3/4" ID X 1.25" OD X 0.075" Thick, Zinc	1
E81062	Washer, 5/16" USS, Zinc	7
E81063	Nut, 5/16"-18, Nylon Lock, Grade 5, Zinc	10
E81064	Screw, 1/4"-20 x 0.750 Hex Head, Grade 5, Zinc	2
E81066	Washer, 3/8" Split Lock, Zinc	4
E81067	Washer, 5/16" Split Lock, Zinc	1
E81071	Rivet, Nylon, Ribbed Shank, 0.281in	2
E81072	Screw, 5/16"-18 x 1.00" Hex Head, Grade 5, Zinc	1
E81076	Nut, 3/8"-16, Nylon Lock, Grade 5, Zinc	4
E81078	Washer, 1/4" Split Lock, Zinc	4
E81079	Nut, 1/2"-14, Jam, Grade 5, Zinc	1
E81080	Screw, 3/8"-16 x 0.750 Hex Head, Grade 5, Zinc	4
E81082	Screw 1/4"-20 x 0.375", Hex Head, Grade 5, Zinc	6
E81085	Screw, Shoulder 1/2" x 0.375" Socket Head	2
E81088	Nut, 1/2"-13, Slim, Nylon Lock, Grade 5, Zinc	1
E81089	Screw, 5/16"-18 x 0.750 Hex Head, Grade 5, Zinc	2
E81107	Motor, 2.5 HP, 36 VDC, 2000 rpm	1
E81123	Wheel, 8" OD, 3/4" ID, Non Marking	2
E81126	Wheel, Caster 2.500, 4 Bolt ASM	1
E81132	Spring, 0.093" Wire, .710" OD x 4.00" L	1
E81141	Cover, Motor, Dust Control	1
E81143	Cover, Dust Bag, Dust Control	1
E81144	Shroud, Dust Control	1
E81149	Pad Driver 19" OD	1
E81150	Pad Holder, Big Mouth & Gripper Ring	1
E81172	Bracket, Adjustment Spring, DCBB	1
E81174	Motor Mount Plate	1
E81229	Knob 2.375 x 1/2"-13 Thread	1
E81275	Threaded Rod, 1/2"-13 x 15.875"	1
E81523	Screw, #8-32 x 3/8" Pan Head, Zinc	3
E81587	Cover, DCBB Base	1
E81598	Axle - 0.750" OD x 19.750" L, Zinc	1
E81604	Gasket, 0.750" x 0.250" x 54.0"	1
E81617	Washer, Flat, 1/4" ID x 1.00" OD, Zinc	2
E81713	Washer, 1/4" SAE, Zinc	10
E83145	Washer, Nylon 1/2" ID X 1.25" OD	4
E83269	Washer, Spring, 1/2" ID	2
E83425	Screw, 1/4"-20 x 0.750 Turss Head	4
E83657	Brush Seal Dust Control, 20.00" OD	1
E83788	Bag, Vacuum, Cloth, Dust Control	1
E88809	DCBB Base Weldment	1
E88810	Motor Pivot Weldment	1
E88885	Dampner, Rubber, Male to Male	4
E88886	Spacer 3/4" ID	2
E88904	Washer, Rubber, 1/2" ID	3
E88913	Lug, 8 AWG, 0.250" Hole, Copper	2
F084620	Pad, 20" Hi-Shine Light Burnish Pad, 5/Case	1

Note: Not available for purchase assembled.

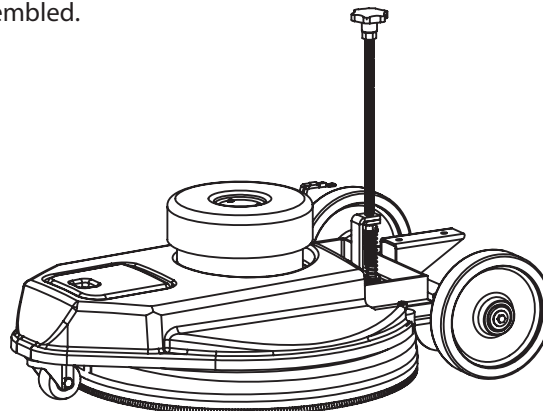

# ELECTRICAL DIAGRAM

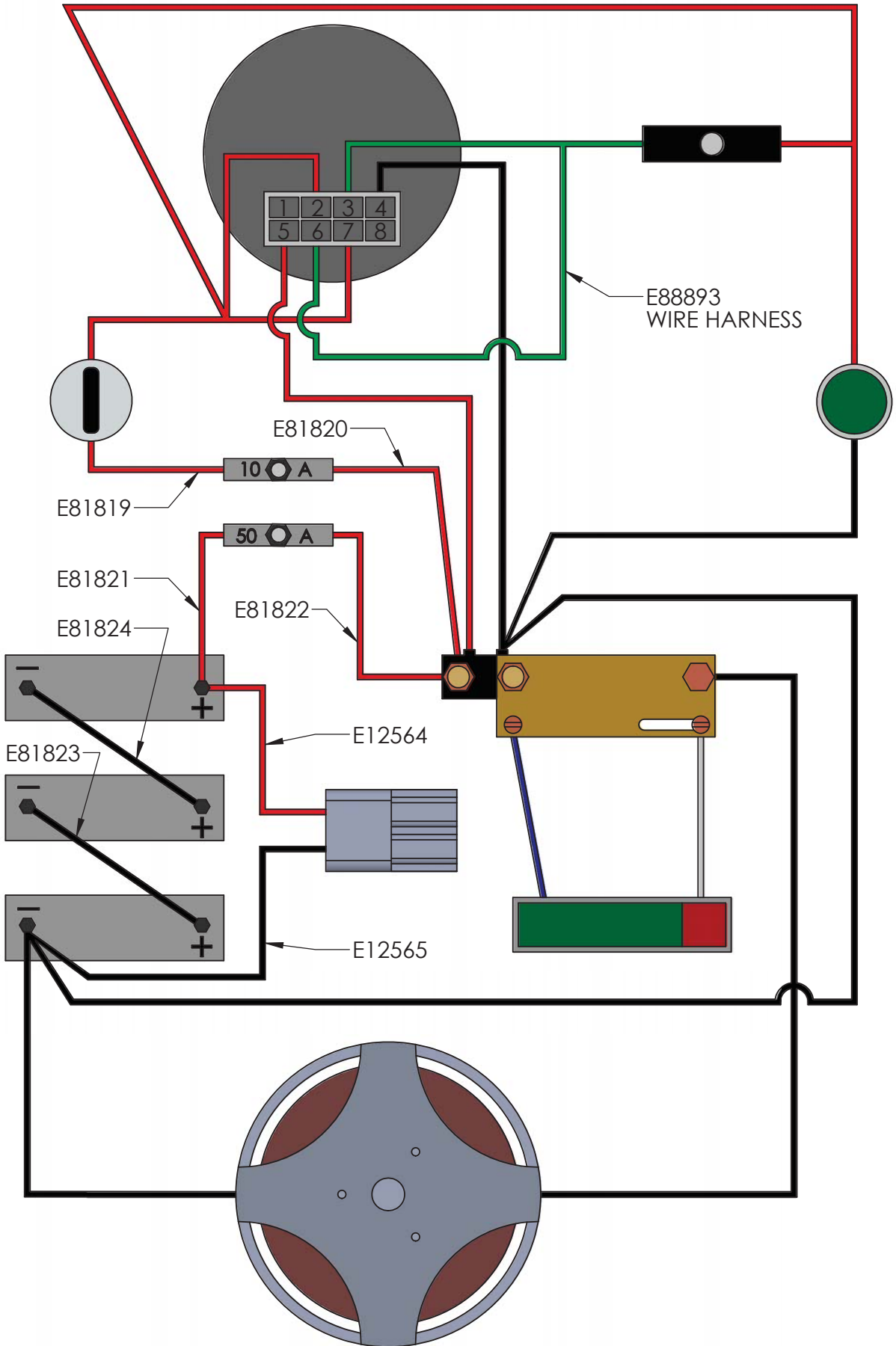

# ELECTRICAL DIAGRAM

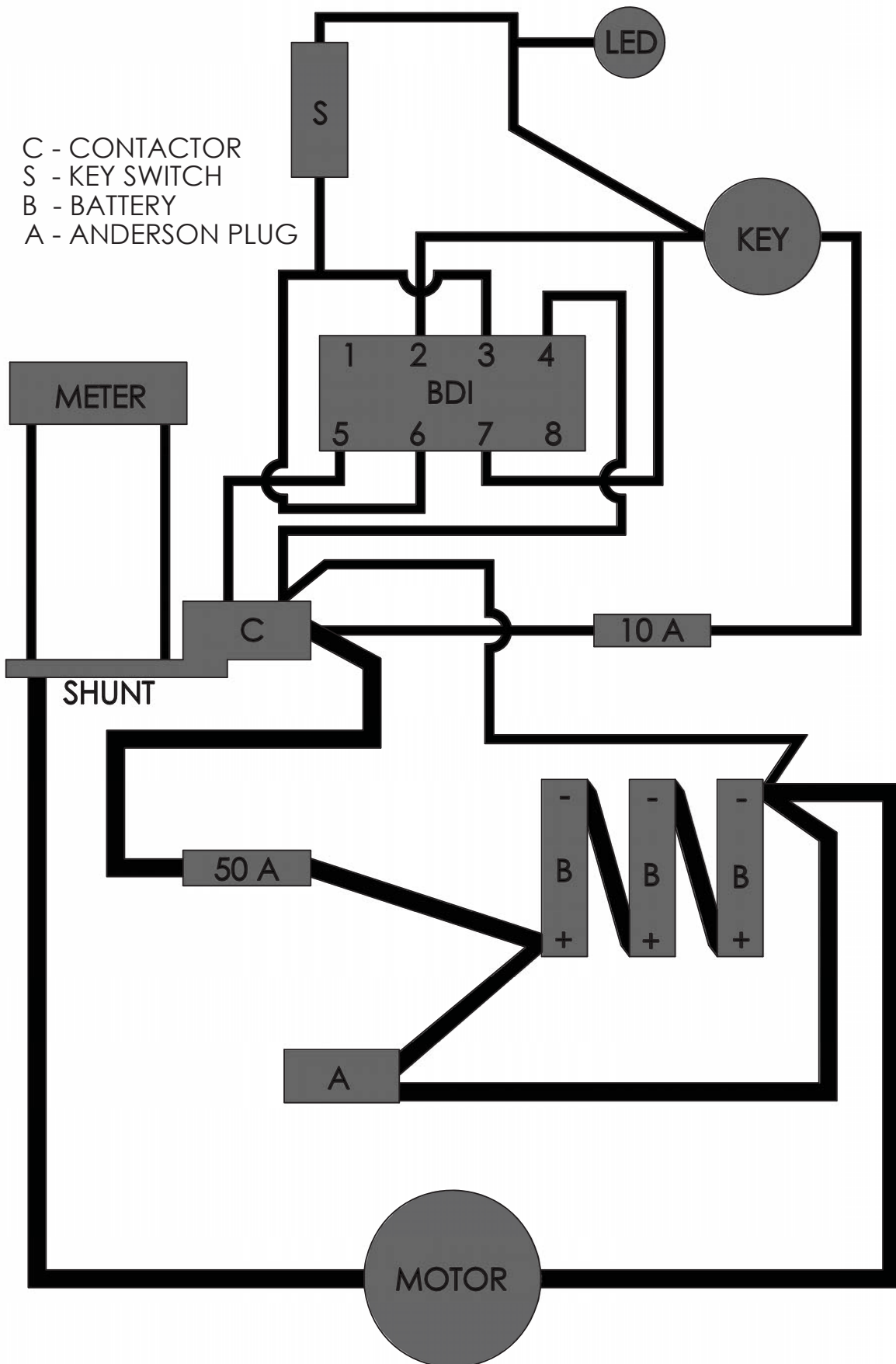

# PARTS LIST

Page	Part #	Description
17	E10734	Screw, 1/4" - 20 x 0.625", Hex Head, Grade 5, Zinc
17	E10878	Anderson Plug, Gray
19	E12407	Washer, 1/2" SAE, Zinc
19	E12476	Screw, Shoulder 1/2" x 0.500" Socket Head
17,20	E12564	Cable, 4 AWG, Red, 27.50" L, Lug 0.250" & Anderson Contact
17,20	E12565	Cable, 4 AWG, Black, 23.50" L, Lug 0.250" & Anderson Contact
17	E12628	Charger, SPE, 36V, 15A, AGM
15	E12629	Switch, Keyed, SPE, With 2 Keys
15	E12630	Hour Meter, BDI
13	E81057	DCBB Handle Tube Weldment
13	E81058	Handle Tube, 0.880" OD x 0.047" Wall x 14.375"
19	E81061	Washer, Flat 3/4" ID X 1.25" OD X 0.075" Thick, Zinc
19	E81062	Washer, 5/16" USS, Zinc
17,19	E81063	Nut, 5/16"-18, Nylon Lock, Grade 5, Zinc
19	E81064	Screw, 1/4"-20 x 0.750" Hex Head, Grade 5, Zinc
19	E81066	Washer, 3/8" Split Lock, Zinc
19	E81067	Washer, 5/16" Split Lock, Zinc
19	E81071	Rivet, Nylon, Ribbed Shank, 0.281in
17,19	E81072	Screw, 5/16"-18 x 1.00" Hex Head, Grade 5, Zinc
15,17	E81074	Screw, #10-24 x 0.500" Pan Head, Zinc
19	E81076	Nut, 3/8"-16, Nylon Lock, Grade 5, Zinc
19	E81078	Washer, 1/4" Split Lock, Zinc
19	E81079	Nut, 1/2"-14, Jam, Grade 5, Zinc
19	E81080	Screw, 3/8"-16 x 0.750 Hex Head, Grade 5, Zinc
19	E81082	Screw 1/4"-20 x 0.375", Hex Head, Grade 5, Zinc
19	E81085	Screw, Shoulder 1/2" x 0.375" Socket Head
19	E81088	Nut, 1/2-13 Nylock Z/P
19	E81089	Screw, 5/16"-18 x 0.750 Hex Head, Grade 5, Zinc
13	E81095	Nut, 1/2"-13, Acorn, Zinc
17	E81097	Screw, 5/16"-18 x 0.500", Grade 5, Hex, Zinc
13	E81099	Screw, 1/4"-20 x 1.000", Pan Head
13	E81105	Plate, Switch
19	E81107	Motor, 2.5 HP, 36 VDC, 2000 rpm
19	E81123	Wheel, 8" OD, 3/4" ID, Non Marking
17	E81125	Wheel, 4" OD, 1/2" ID, Non Marking

Page	Part #	Description
19	E81126	Wheel, Caster 2.500, 4 Bolt
19	E81132	Spring, 0.093" Wire, .710" OD x 4.00" L
13	E81139	Wire, 16 AWG, Black, 4.00" L, 1 Female QD
19	E81141	Cover, Motor, Dust Control
19	E81143	Cover, Dust Bag, Dust Control
19	E81144	Shroud, Dust Control
17	E81146	Cover, Battery, DCBB
19	E81149	Pad Driver 19" OD
19	E81150	Pad Holder, Big Mouth & Gripper Ring
19	E81172	Bracket, Adjustment Spring, DCBB
19	E81174	Motor Mount Plate
13	E81175	Bracket, Handle Leg DCBB
15	E81178	Bracket, Hour Meter
13	E81180	Serial Number Decal
19	E81229	Knob 2.375 x 1/2"-13 Thread
13,19	E81275	Threaded Rod, 1/2"-13 x 15.875"
13	E81278	Pilot Light 36 VDC
17	E81400	Collar, Shaft 0.500" ID, Set Screw
19	E81523	Screw, #8-32 x 3/8" Pan Head, Zinc
15	E81528	Contacto 36VDC, 72 Amp
13	E81569	Switch Box, Battery Burnisher
17	E81584	Nut, #10-24, Zinc
17	E81586	Hinge, Piano, 10.00" x 1.50", Steel, Chrome
19	E81587	Cover, DCBB Base
13	E81588	Meter 50 mV 1-50 AMP, Scale Green 0-40
15	E81589	Shunt, 50 AMP, 50 mV
17	E81590	Lanyard, 0.065" x 24.00" L
15	E81596	Manual Reset Circuit Protector 50 AMP
15	E81597	Manual Reset Circuit Protector 10 AMP
19	E81598	Axle - 0.750" OD x 19.750" L, Zinc
17	E81599	Axle, 0.500" OD x 2.250" L
17	E81602	Axle, 0.500" OD x 15.375" L, Zinc
17,19	E81604	Gasket, 0.750" x 0.250" x 54.0"
19	E81617	Washer, Flat, 1/4" ID x 1.00" OD, Zinc
17,19	E81713	Washer, 1/4" SAE, Zinc

Page	Part #	Description
15	E81760	Screw, 1/4"-20 x 3/4" Hex Head, Brass
15	E81761	Washer, 1/4" SAE, Brass
15,20	E81819	Wire, 16 AWG, Red, 4.00" L, 2 Female QD
15,20	E81820	Wire, 16 AWG, Red, 6.00" L, Female QD & Ring 0.250"
17,20	E81821	Cable, 6 AWG, Red, 21.50" L, Lug 0.250" & Lug #10
15,20	E81822	Cable, 6 AWG, Red, 6.00" L, Lug #10 & Lug 0.250"
17,20	E81823	Cable, 6 AWG, Black, 6.50" L, 2 Lugs 0.250"
17,20	E81824	Cable, 6 AWG, Black 23.50" L, 2 Lugs 0.250"
15	E81842	Nut, 1/4"-20, Hex Head, Brass
15,17	E81843	Screw, M4 x 7mm, Pan Head, Zinc
13	E82749	Handle Trigger Switchbox
13	E82751	Cover, Switch Box
13	E83127	Handle Grip 7/8" ID
13	E83129	Safety Lock
13	E83130	Spring, Extension 0.026 Wire x 0.686 L
17	E83143	Axle Cap 0.500"
19	E83145	Washer, Nylon 1/2" ID X 1.25" OD
19	E83269	Washer, Spring, 1/2" ID"
13	E83270	Spring Clip
19	E83425	Screw, 1/4"-20 x 0.750 Hex Head
13	E83426	Screw, 1/4"-20 x 1.750, Pan Head
13	E83427	Screw, #6-32 x 1.00", Pan Head
13	E83522	Wire Nut, Yellow
17	E83523	Wire tie
19	E83657	Brush Seal Dust Control, 20.00" OD
13	E83691	Decal, Warning
17	E83720	Decal, Adjustment DC Burnishe
13	E83731	Decal, Handle, Dust Control Burnisher"
19	E83788	Bag, Vacuum, Cloth, Dust Control
13	E85032	Switch, 25 AMP, 1.5 HP, 125 VAC
17	E86157	60" Long Wire Tie
17	E88030	Battery, Crown, 12 VDC, 110 AH, AGM
19	E88809	DCBB Base Weldment
19	E88810	Motor Pivot Weldment
19	E88885	Dampner, Rubber, Male to Male

Page	Part #	Description
19	E88886	Spacer 3/4" ID
17	E88887	Bracket, Battery Support Weldment
17,20	E88893	Wire Harness, 16 AWG, 6 Wire, Molex 5557-08R Connector
17	E88894	Battery Box Weldment
19	E88904	Washer, Rubber, 1/2" ID
17	E88909	Nut, #10-24, Nylon Lock, Grade 5, Zinc
19	E88913	Lug, 8 AWG, 0.250" Hole, Copper
15	E89382	Key, Switch
19	F084620	Pad, 20" Hi-Shine Light Burnish Pad, 5/Case

# CREWMAN™ DUST CONTROL BATTERY BURNISHER MAINTENANCE

<b>PERIODIC MAINTENANCE</b> PLEASE REFER OWNERS MANUAL FOR MORE INFORMATION	<b>DAILY</b>	<b>EVERY 25 HOURS</b>	<b>EVERY 50 HOURS</b>	<b>EVERY 100 HOURS</b>	<b>EVERY 250 HOURS</b>
Empty the dust bag	*				
Wipe the machine with a damp cloth	*				
Charge batteries	*				
Make sure battery connections are tight and free from corrosion			*		
Inspect vibration mounts				*	
Check & tighten nuts and screws				*	
Check the dust shroud and brush seal				*	
Check the motor brushes for wear or excessive arcing					*
Change vibration mounts					*
Check the cables, wires & electrical system for wear or damage					*
Check the safety lockout on the trigger					*
Check wheels and bearings					*

**IMPORTANT NOTES:**

- 1) Warning - Unplug the machine charger before servicing
- 2) Maintenance should be done by qualified personnel only



# TROUBLESHOOTING

PROBLEM	CAUSE	POSSIBLE SOLUTION
No power, green power lamp is off, no BDI readout.	Bad connection	Check all connections
	Bad connection to BDI	Make sure connector is fully pushed into BDI
	Batteries dead	Recharge or replace batteries as needed
	Battery terminals disconnected	ensure all terminal connections are clean and secure
Power is on but won't run	Circuit breakers tripped	Turn off key switch and push each circuit breaker
Floor not polished	Not enough pad pressure	Increase pressure using pad pressure adjustment knob inside battery box
	Pad worn out	Change pad and adjust pad pressure knob inside battery box
Low runtime	Improper charge	Make sure that batteries get a full charge after each use
	Batteries damaged or old	Test & replace batteries. Best to replace as a set
	Too much pad pressure.	Decrease pressure using pad pressure adjustment knob inside battery box
	Too much pad pressure	Decrease pressure using pad pressure adjustment knob inside battery box
	BDI voltage set to too high	See BDI instruction page for proper BDI setting
Excessive vibration	Pad not centered	Remove pad, rotate 45° & re-center the pad
	Pad is torn or worn excessively	Replace pad
Batteries are not charging	Charger plugged in but not on	Check wall outlet circuit breaker
	Charger plugged in and on but batteries not charged	Ensure gray Anderson plug is snapped together
	Dirty battery terminals	Check all battery cable connections, clean and secure the cables back onto the connections
	Batteries damaged or old	Test & replace batteries. Recommend to replace as a set
	Charger may be damaged	Inspect charger
Nothing here fixes the problem	Problem could have several causes	Contact your local service center





# BETCO US WARRANTY POLICY

## 10 year coverage

Subject to the conditions stated below, Betco warrants parts and labor on rotationally molded polyethylene tanks/housings and injection molded vacuum head assemblies to be free from defects in materials and workmanship for a period of ten years to the original purchaser.

## 3 Year Coverage

Subject to the conditions stated below, Betco warrants parts and labor on all other Betco components to be free from defects in materials and workmanship for a period of three years to the original purchaser.

## 1 Year Coverage

Subject to the conditions stated below, Betco offers a limited warranty on parts and labor on the following equipment: parts and accessories to be free from defects in materials and workmanship for a period of one year to the original purchaser.

- DM Series Vacuums: #85506-00, #85507-00
- Bac Pac Lite Vacuum: #85903-00
- FiberPRO® Floor Dryer: #85507-00
- WORKMAN™ Series Vacuums: #85024-00, #85025-00, #85026-00, #85027-00
- CV100T Vacuum: #85023-00
- All Tools and Accessories
- All Battery Chargers
- All Batteries are pro-rated for 1 year

### **Allowable Travel Time Warranty Reimbursement:**

Eligible equipment: All battery and propane powered equipment products. Warranty period: 90 days from date of sale to the original purchaser. A maximum 60 mile round trip at 44 cents per mile will be allowed for warranty consideration.

### **Propane Machine Warranty:**

Honda engines are warranted by Honda for a period of 2 years against manufacturer defects. Kawasaki engines are warranted by Kawasaki for a period of 2 years against manufacturer defects. All other components (except wear items)\* are warranted by Betco for a period of 3 years.

**\*Wear Items exempt from Warranty consideration include but may not be limited to: power cords, transport wheels, vacuum bags, belts, squeegee blades, pad drivers, clutch plates, handle grips, filters, screens, throttle cables, brushes and carbon brushes.**

Subject to the conditions and exceptions stated in this warranty, Betco warrants the Betco products to be free from defects in material and workmanship, under normal use and service, for the periods listed under the warranty policy to the original purchaser. At any time during the warranty period, Betco will furnish replacement parts for the Betco parts to the original purchaser. Such parts will be furnished and charged including transportation costs, to the original owner through any Betco authorized Service Distributor. If the original part is returned within the warranty policy period from date of delivery for inspection by Betco and is found to be defective the owner will be credited for the cost of replacement parts plus shipping and handling. Replacement parts that have become defective through wear or abuse are not included in this warranty.

This warranty does not apply to damage or defect caused by accident, misuse, negligence, fire, or to any Betco product which has been serviced or repaired by other than an authorized Betco Service Distributor or Betco factory personnel. This warranty is void if products are used for any purpose other than that which was intended. There are no other warranties expressed or implied. In no event shall Betco be liable for incidental or consequential damages or any damage to person or property. (Please note some states do not allow the exclusion or limitations for incidental and consequential damages)

